



Aurora Utilities Limited

Use of System Charging Statement

NOTICE OF CHARGES

Effective from 1st April 2026

Version 1.0

Version Control

Version	Date	Description of version and any changes made
1.0	30/01/2025	Final Charges effective from 1 st April 2026

Contents

1. Introduction	5
Validity period	6
Contact details	7
2. Charge application and definitions	8
The Supercustomer/Aggregated and site-specific billing approaches	8
Supercustomer / Aggregated billing and payment	9
Site-specific billing and payment	11
Components of Charges	12
Allocation of charges	18
Generation charges for pre-2005 designated EHV properties	20
Provision of billing data	21
Out of area use of system charges	22
Licensed distribution network operator charges	22
Licence exempt distribution networks	23
3. Schedule of charges for use of the distribution system	26
4. Schedule of line loss factors	27
Role of line loss factors in the supply of electricity	27
Calculation of line loss factors	27
Publication of line loss factors	28
5. Notes for Designated EHV Properties	30
EDCM network group costs	30
Charges for new Designated EHV Properties	30
Charges for amended Designated EHV Properties	30
Demand-side management	30
6. Electricity distribution rebates	32
7. Accounting and administration services	32
8. Charges for electrical plant provided ancillary to the grant of use of system	32
9. Schedule of fixed adders to recover Supplier of Last Resort and Eligible Bad Debt pass-through costs	32
10. Non-Final Demand Sites	34
11. Back-up Connections	35
Appendix 1 - Glossary	38
Appendix 2 - Guidance notes	48
Background	48
Meter point administration	48
Your charges	50
Reducing your charges	51
Reactive power and reactive power charges	51
Site-specific EDCM charges	52
Appendix 3 – Non-Final Demand Site Certificate	55

Annex 1 - Schedule of charges for use of the distribution system by LV and HV Designated Properties, and Unmetered Supplies	57
Annex 2 - Schedule of charges for use of the distribution system by Designated EHV Properties (including LDNOs with Designated EHV Properties/end-users)	57
Annex 3 - Schedule of charges for use of the distribution system by preserved/additional LLF classes	57
Annex 4 - Charges applied to LDNOs with LV and HV end-users	57
Annex 5 - Schedule of line loss factors	57
Annex 6 - Charges for New or Amended Designated EHV Properties	57
Annex 7 - Final Supplier of Last Resort and Bad Debt Pass-through Costs	57

1. Introduction

- 1.1. This statement tells you about our charges and the reasons behind them. It has been prepared consistent with Standard Licence Condition 14 of our Electricity Distribution Licence. The main purpose of this statement is to provide our schedule of charges¹ for the use of our Distribution System and to provide the schedule of Line Loss Factors² that should be applied in Settlement to account for losses from the Distribution System. We have also included guidance notes in Appendix 2 to help improve your understanding of the charges we apply.
- 1.2. Within this statement we use terms such as 'Users' and 'Customers' as well as other terms which are identified with initial capitalisation. These terms are defined in the glossary.
- 1.3. This statement reflects the changes which have been introduced as a result of Market Wide Half Hourly Settlement (MHHS³). Although the existing arrangements will continue to apply for Non-Migrated MPANs, the MHHS arrangements will be effective for any MPAN that has Migrated, any differences in treatment are highlighted throughout the document.
- 1.4. The charges in this statement are calculated using the following methodologies as per the Distribution Connection and Use of System Agreement (DCUSA)⁴:
 - Common Distribution Charging Methodology (CDCM); for Low Voltage (LV) and High Voltage (HV) Designated Properties as per DCUSA Schedule 16;
 - Extra High Voltage (EHV) Distribution Charging Methodology (EDCM); for Designated EHV Properties as per DCUSA Schedule 17 or 18;

¹ Charges can be positive or negative.

² Known as adjustment factors in the Distribution Licence and commonly referred to as Loss Adjustment Factors. The schedule of Line Loss Factors will be provided in a revised statement shortly after the Line Loss Factors for the relevant year have been successfully audited by Elexon.

³ Information relating to the Market wide HH Settlement Programme available from [Home - MHHS Programme](#)

⁴ Distribution and Connection Use of System Agreement (DCUSA) available from [DCUSA Document - DCUSA](#)

- Price Control Disaggregation Model (PCDM); for Discount Percentages used to calculate the LDNO Use of System charges in the CDCM and EDCM as per DCUSA Schedule 29.
- 1.5. Separate charges are calculated depending on the characteristics of the connection and whether the use of the Distribution System is for demand or generation purposes. Where a generation connection is seen to support the Distribution System the charges will be negative and the Supplier will receive credits for exported energy.
 - 1.6. The application of charges to premises can usually be referenced using the Line Loss Factor Class (LLFC)/DUoS Tariff ID contained in the charge tables. Further information on how to identify and calculate the charge that will apply for your premises is provided in the guidance notes in Appendix 2.
 - 1.7. All charges in this statement are shown **exclusive** of VAT. Invoices will include VAT at the applicable rate.
 - 1.8. The annexes that form part of this statement are also available in spreadsheet format⁵. This spreadsheet contains supplementary information used for charging purposes and a simple model to assist you to calculate charges. This spreadsheet can be downloaded from <https://aurora-utilities.co.uk/>

Validity period

- 1.9. This charging statement is valid for services provided from the effective date stated on the front of the statement and remains valid until updated by a revised version or superseded by a statement with a later effective date.
- 1.10. When using this charging statement, care should be taken to ensure that the relevant statement or statements covering the period that is of interest are used.
- 1.11. Notice of any revision to the statement will be provided to Users of our Distribution System (with the exception of updates to Annex 6; New or Amended

EHV Sites which will be published as an addendum). The latest statements can be downloaded from <https://aurora-utilities.co.uk/>

Contact details

1.12. If you have any questions about this statement please contact us at this address:

Aurora Utilities
5th Floor
Tower 42
25 Old Broad Street
London
EC2N 1HN
Email: info@aurora-utilities.co.uk
Telephone: 020 3023 0200

1.13. For all other queries please contact our general enquiries telephone number: 020 3023 0200; lines are open 09.00 – 17.00 Monday to Friday.

2. Charge application and definitions

2.1. The following section details how the charges in this statement are applied and billed to Users of our Distribution System.

The Supercustomer/Aggregated and site-specific billing approaches

2.2. We utilise two billing approaches depending on the type of metering data received:

- The Supercustomer / Aggregated approach for Customers for whom we receive aggregated consumption data through Settlement; and
- The 'Site-specific' approach for Customers for whom we receive site-specific consumption data through Settlement.

2.3. We receive aggregated consumption data through Settlement for:

Non-Migrated MPANs:

- Domestic and non-domestic Customers for whom Non-Half Hourly (NHH) metering data is used in Settlement (i.e. Customers with MPANs which are registered to Measurement Class A);
- Customers which are unmetered and are not settled as pseudo Half Hourly (HH) metered (i.e. Customers with MPANs which are registered to Measurement Class B);
- Domestic Customers for whom HH metering data is used in Settlement (i.e. Customers with MPANs which are registered to Measurement Class F); and
- Non-domestic Customers for whom HH metering data is used in Settlement and which have whole current (WC) metering (i.e. Customers with MPANs which are registered to Measurement Class G).

Migrated MPANs:

All Customers who have a Connection Type that indicates a Whole Current connection, i.e. with Connection Type 'W'.

2.4. We receive site-specific consumption data through Settlement for:

Non-Migrated MPANs:

- Customers for whom HH metering data is used in Settlement and which have current transformer (CT) metering (i.e. Customers with MPANs which are registered to Measurement Class C or E); and
- Customers which are unmetered and settled as pseudo HH metered (i.e. Customers with MPANs which are registered to Measurement Class D).

Migrated MPANs:

All Customers who have a Connection Type of 'L' Low Voltage, 'H' High Voltage, 'E' Extra-High Voltage or 'U' Unmetered.

Supercustomer / Aggregated billing and payment

2.5. The Supercustomer / Aggregated approach makes use of aggregated data obtained from Suppliers using the 'Aggregated Distribution Use of System (DUoS) Report' data flow for Non-Migrated MPANs, and the 'LDSO report for DUoS – aggregated data' message or the 'Embedded Network report for DUoS – aggregated data' message for Migrated MPANs.

2.6. Invoices are calculated on a periodic basis and sent to each User for whom we transport electricity through our Distribution System. Invoices are reconciled over a period of approximately 14 months to reflect later and more accurate consumption figures, this will reduce to four months following MHHS implementation).

2.7. The charges are applied on the basis of the LLFC/DUoS Tariff ID assigned to the MPAN, and the units consumed within the time periods specified in Annex 1. All LLFCs/DUoS Tariff IDs are assigned at our sole discretion, based on the tariff application rules set out in the appropriate charging methodology or elsewhere

in this statement. Please refer to the section '**Error! Reference source not found.**' if you believe the allocated LLFC/DUoS Tariff ID or tariff is incorrect.

Supercustomer / Aggregated charges

- 2.8. Supercustomer / Aggregated charges include the following components:
- a fixed charge, pence/MPAN/day, there will only be one fixed charge applied to each MPAN; and
 - unit charges, pence/kilowatt-hour (kWh); three unit charges will apply depending on the time of day and the type of tariff for which the MPAN is registered.
- 2.9. Users who wish to supply electricity to Customers for whom we receive aggregated data through Settlement (see paragraph 2.3) will be allocated the relevant charge structure set out in Annex 1.
- 2.10. Identification of the appropriate charge can be made by cross-reference to the LLFC/DUoS Tariff ID.
- 2.11. For Non-Migrated MPANs the Valid Settlement Profile Class (PC)/Standard Settlement Configuration (SSC)/Meter Timeswitch Code (MTC) combinations for LLFC where the Metering System is Measurement Class A or B are detailed in Market Domain Data (MDD). For Migrated MPANs the appropriate reference data is contained in Industry Standing Data (ISD).
- 2.12. Where an MPAN has an invalid Settlement combination, the 'Domestic Aggregated with Residual' fixed and unit charges will be applied as default until the invalid combination is corrected. Where there are multiple SSC/TPR combinations for Non-Migrated MPANs, the default 'Domestic Aggregated with Residual' fixed and unit charges will be applied for each invalid SSC/TPR combination.

2.13. The ‘Domestic Aggregated (related MPAN)’ and ‘Non-Domestic Aggregated (related MPAN)’ charges are supplementary to their respective primary MPAN charge.

Site-specific billing and payment

2.14. The site-specific billing and payment approach makes use of HH metering data at premises level received through Settlement.

2.15. Invoices are calculated on a periodic basis and sent to each User for whom we transport electricity through our Distribution System. Where an account is based on estimated data, the account shall be subject to any adjustment that may be necessary following the receipt of actual data from the User.

2.16. The charges are applied on the basis of the LLFC/DUoS Tariff ID assigned to the MPAN (or the (MSID) for Central Volume Allocation (CVA) sites), and the units consumed within the time periods specified in this statement.

2.17. All LLFCs/DUoS Tariff IDs are assigned at our sole discretion, based on the tariff application rules set out in the appropriate charging methodology or elsewhere in this statement. Please refer to the section ‘Allocation of charges’ if you believe the allocated LLFC/DUoS Tariff ID or tariff is incorrect. Where an incorrectly applied LLFC/DUoS Tariff ID is identified, we may at our sole discretion apply the correct LLFC/DUoS Tariff ID and/or charges.

Site-specific billed charges

2.18. Site-specific billed charges for LV and HV Designated Properties may include the following components:

- a fixed charge, pence/MPAN/day or pence/MSID/day;
- a capacity charge, pence/kilovolt-ampere (kVA)/day, for Maximum Import Capacity (MIC) and/or Maximum Export Capacity (MEC);
- an excess capacity charge, pence/kVA/day, if a site exceeds its MIC and/or MEC;

- three unit charges, pence/kWh, depending on the time of day and the type of tariff for which the MPAN is registered; and
 - a reactive power charge, pence/kilovolt-ampere reactive hour (kVArh), for each unit in excess of the reactive charge threshold.
- 2.19. Site-specific billed charges for properties that are under transitional protection arrangements for BSC Modification P432 or MHHS will include only fixed and unit charges, in the same manner as Supercustomer / Aggregate charges, as described in 2.8.
- 2.20. Users who wish to supply electricity to Customers for whom we receive site-specific data through Settlement (see paragraph 2.4) will be allocated the relevant charge structure dependent upon the voltage and location of the Metering Point.
- 2.21. Fixed charges are generally levied on a pence per MPAN/MSID per day basis.
- 2.22. LV and HV Designated Properties will be charged in accordance with the CDCM and allocated the relevant charge structure set out in Annex 1.
- 2.23. Designated EHV Properties will be charged in accordance with the EDCM and allocated the relevant charge structure set out in Annex 2.
- 2.24. Where LV and HV Designated Properties or Designated EHV Properties have more than one point of connection (as identified in the Connection Agreement) then separate charges will be applied to each point of connection.

Components of Charges

Application of Residual Charges

- 2.25. The following sections explain the application of residual charges.

Final Demand Sites

- 2.26. Residual charges are recovered through fixed charges for all Final Demand Sites. All Non-Final Demand Sites must submit a valid certificate, as described in

Section 10, and upon receipt of a valid certificate will be allocated to the relevant No Residual tariff.

2.27. All Back-up Connections must provide clear supporting documentary evidence to the reasonable satisfaction of the LDNO, as described in Section 11, and upon receipt of sufficient evidence will be allocated to the relevant No Residual tariff.

Residual Charging Bands

2.28. Residual charges are applied to Final Demand Sites on a banded basis, with all sites in a given charge band receiving the same residual charge. Domestic customers have a single charging band.

2.29. There are four non-domestic charging bands for each of the following groups:

- Designated Properties connected at LV, billing with no MIC;
- Designated Properties connected at LV, billing with MIC;
- Designated Properties connected at HV; and
- Designated EHV Properties.

2.30. All non-domestic Final Demand customers are allocated into one of the four charging bands, for each relevant charge structure.

2.31. The residual charging band boundaries are calculated nationally based upon data from all LDNOs. The method and timing for calculating the residual charging band boundaries and the method and timing for allocating customers into the residual charging bands are set out in Schedule 32 of DCUSA.

2.32. The boundaries for the residual bands can be found in the 'Schedule of charges and other tables' spreadsheet on our website, as well as the mapping between the DUoS Tariff name and TNUOS site charging band.

Time periods

- 2.33. The time periods for the application of unit charges to metered LV and HV Designated Properties are detailed in Annex 1. We have not issued a notice to change the time bands.
- 2.34. The time periods for the application of unit charges to Unmetered Supply Exit Points are detailed in Annex 1. We have not issued a notice to change the time bands.
- 2.35. The time periods for the application of unit charges to Designated EHV Properties are detailed in Annex 2. We have not issued a notice to change the time bands.

Application of capacity charges

- 2.36. The following sections explain the application of capacity charges and exceeded capacity charges.

Chargeable capacity

- 2.37. The chargeable capacity is, for each billing period, the MIC/MEC, as detailed below.
- 2.38. The MIC/MEC will be agreed with us at the time of connection or pursuant to a later change in requirements. Following such an agreement (be it at the time of connection or later) no reduction in MIC/MEC will be allowed for a 12 month period.
- 2.39. Reductions to the MIC/MEC may only be permitted once in a 12 month period. Where the MIC/MEC is reduced the new lower level will be agreed with reference to the level of the Customer's maximum import and/or export demand respectively. The new MIC/MEC will be applied from the start of the next billing period after the date that the request was received. It should be noted that, where a new lower level is agreed, the original capacity may not be available in the future without the need for network reinforcement and associated charges.
- 2.40. In the absence of an agreement, the chargeable capacity, save for error or omission, will be based on the last MIC/MEC that we have previously agreed for

the relevant premises' connection. A Customer can seek to agree or vary the MIC/MEC by contacting us using the contact details in section 1.12.

Exceeded capacity

2.41. Where a Customer takes additional unauthorised capacity over and above the MIC/MEC, the excess will be classed as exceeded capacity. The exceeded portion of the capacity will be charged at the excess capacity charge p/kVA/day rate, based on the difference between the MIC/MEC and the actual capacity used. This will be charged for the full duration of the billing period in which the breach occurs.

Demand exceeded capacity

$$\text{Demand exceeded capacity} = \max(2 \times \sqrt{AI^2 + \max(RI, RE)^2} - MIC, 0)$$

Where:

AI = Active import (kWh)

RI = Reactive import (kVArh)

RE = Reactive export (kVArh)

MIC = Maximum import capacity (kVA)

2.42. Only reactive import and reactive export values occurring at times of active import are used in the calculation. Where data for two or more MPANs is aggregated for billing purposes the HH consumption values are summated prior to the calculation above. For sites which are importing and exporting in the same half hour, i.e. where active import is not equal to zero and active export is not equal to zero, use zero for reactive import and reactive export when calculating capacity taken.

2.43. This calculation is completed for every half hour and the maximum value from the billing period is applied.

Generation exceeded capacity

$$\text{Generation exceeded capacity} = \max(2 \times \sqrt{AE^2 + \max(RI, RE)^2} - MEC, 0)$$

Where:

AE = Active export (kWh)

RI = Reactive import (kVArh)

RE = Reactive export (kVArh)

MEC = Maximum export capacity (kVA)

2.44. Only reactive import and reactive export values occurring at times of active export are used in the calculation. Where data for two or more MPANs is aggregated for billing purposes the HH consumption values occurring at times of kWh export are summated prior to the calculation above. For sites which are importing and exporting in the same half hour, i.e. where active import is not equal to zero and active export is not equal to zero, use zero for reactive import and reactive export when calculating capacity taken.

2.45. This calculation is completed for every half hour and the maximum value from the billing period is applied.

Standby capacity for additional security on site

2.46. Where standby capacity charges are applied, the charge will be set at the same rate as that applied to normal MIC. Should a Customer's request for additional security of supply require the provision of capacity from two different sources, we reserve the right to charge for the capacity held at each source.

Minimum capacity levels

2.47. There is no minimum capacity threshold.

Application of charges for excess reactive power

2.48. When an individual HH metered MPAN's reactive power (measured in kVArh) at LV and HV Designated Properties exceeds 33% of its total active power

(measured in kWh) in any given half hour, excess reactive power charges will apply. This threshold is equivalent to an average power factor of 0.95 during that half hour. Any reactive units in excess of the 33% threshold are charged at the rate appropriate to the particular charge.

2.49. Power Factor is calculated as follows:

$\cos \theta = \text{Power Factor}$

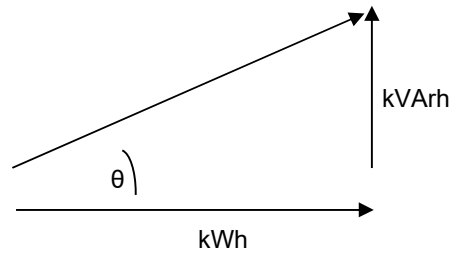

2.50. The chargeable reactive power is calculated as follows:

Demand chargeable reactive power

$$\text{Demand chargeable kVArh} = \max \left(\max(RI, RE) - \left(\sqrt{\left(\frac{1}{0.95^2} - 1 \right)} \times AI \right), 0 \right)$$

Where:

AI = Active import (kWh)

RI = Reactive import (kVArh)

RE = Reactive export (kVArh)

2.51. Only reactive import and reactive export values occurring at times of active import are used in the calculation. Where data for two or more MPANs is aggregated for billing purposes the HH consumption values are summated prior to the calculation above. For sites which are importing and exporting in the same half hour i.e. where active import is not equal to zero and active export is not

equal to zero, no calculation for that half hour is made and the result for that half hour would be zero.

2.52. The square root calculation will be to two decimal places.

2.53. This calculation is completed for every half hour and the values summated over the billing period.

Generation chargeable reactive power

$$\text{Generation chargeable kVArh} = \max \left(\max(RI, RE) - \left(\sqrt{\left(\frac{1}{0.95^2} - 1 \right) \times AE}, 0 \right) \right)$$

Where:

AE = Active export (kWh)

RI = Reactive import (kVArh)

RE = Reactive export (kVArh)

2.54. Only reactive import and reactive export values occurring at times of active export are used in the calculation. Where data for two or more MPANs is aggregated for billing purposes the HH consumption values are summated prior to the calculation above. For sites which are importing and exporting in the same half hour i.e. where active import is not equal to zero and active export is not equal to zero, no calculation for that half hour is made and the result for that half hour would be zero.

2.55. The square root calculation will be to two decimal places.

2.56. This calculation is completed for every half hour and the values summated over the billing period.

Allocation of charges

2.57. It is our responsibility to apply the correct charges to each MPAN/MSID. The allocation of charges is based on the voltage of connection, import/export

details including multiple MPANs, metering information and, for some tariffs, the metering location.

- 2.58. We are responsible for deciding the voltage of connection. Generally this is determined by where the metering is located and where responsibility for the electrical equipment transfers from us to the connected Customer.
- 2.59. We are also responsible for allocating non-domestic customers into their residual charging bands. Allocation into residual charging bands is determined by consumption for customers billed under the Supercustomer / Aggregated approach and for properties that are under transitional protection arrangements for BSC Modification P432 or MHHS, and by the MIC for all other customers billed under the site-specific approach.
- 2.60. The Supplier determines and provides us with the metering information and data to enable us to allocate charges. The metering information and data is likely to change over time if, for example, a Supplier changes an MPAN from non-domestic to domestic following a change of use at the premise. When we are notified this has happened we will change the allocation of charges accordingly.
- 2.61. If it has been identified that a charge may have been incorrectly allocated due to the metering information and/or data then a request for investigation should be made to the Supplier.
- 2.62. Where it has been identified that a charge is likely to be incorrectly allocated due to the voltage of connection; import/export details; metering location; or allocation to residual charging band then a request to investigate the applicable charges should be made to us. Requests from persons other than the Customer or the current Supplier must be accompanied by a Letter of Authority from the Customer; the current Supplier must also acknowledge that they are aware a request has been made. Any request must be supported by an explanation of why it is believed that the current charge should be changed, along with supporting

information including, where appropriate, photographs of metering positions or system diagrams. Any request to change the current charge that also includes a request for backdating must include justification as to why it is considered appropriate to backdate the change.

- 2.63. Where a residual charging band allocation cannot be resolved, the dispute process provided within DCUSA Schedule 32 should be followed.
- 2.64. An administration charge (covering our reasonable costs) may be made if a technical assessment or site visit is required, but we will not apply any charge where we agree to the change request.
- 2.65. Where we agree that the current LLFC/DUoS Tariff ID charge should be changed, we will then allocate the appropriate set of charges for the connection. Any adjustment will be applied from the date of the request, back to either the date of the incorrect allocation, or up to the maximum period specified by the Limitation Act (1980) in England and Wales, which covers a six year period from the date of request, and the Prescription and Limitation (Scotland) Act 1973, which covers a five year period from the date of request; whichever is the shorter.
- 2.66. Any credit or additional charge will be issued to the relevant Supplier(s) effective during the period of the change.
- 2.67. Should we reject the request (as per paragraph 2.62) a justification will be provided to the requesting party. We shall not unreasonably withhold or delay any decision on a request to change the charges applied and would expect to confirm our position on the request within three months of the date of request.

Generation charges for pre-2005 designated EHV properties

- 2.68. Designated EHV Properties that were connected to the Distribution System under a pre-2005 connection charging policy are eligible for exemption from Use of System (UoS) charges for generation unless one of the following criteria has been met:

- 25 years have passed since their first energisation/connection date (i.e. Designated EHV Properties with Connection Agreements dated prior to 1st April 2005, and for which 25 years has passed since their first energisation/connection date will receive UoS charges for generation from the next charging year following the expiry of their 25 years exemption, (starting 1st April), or
- the person responsible for the Designated EHV Property has provided notice to us that they wish to opt in to UoS charges for generation.

If a notice to opt in has been provided there will be no further opportunity to opt out.

2.69. Furthermore, if an exempt Customer makes an alteration to its export requirement then the Customer may be liable to be charged for the additional capacity required for energy imported or exported. For example, where a generator increases its export capacity the incremental increase in export capacity will attract UoS charges as with other non-exempt generators.

Provision of billing data

2.70. Where HH metering data is required for UoS charging and this is not provided in accordance with the BSC or DCUSA, such metering data shall be provided to us by the User of the system in respect of each calendar month within five working days of the end of that calendar month.

2.71. The metering data shall identify the amount of energy conveyed across the Metering System in each half hour of each day and shall separately identify active and reactive import and export. Metering data provided to us shall be consistent with that received through the metering equipment installed.

2.72. Metering data shall be provided in an electronic format specified by us from time to time and, in the absence of such specification, metering data shall be

provided in a comma-separated text file in the format of data flow D0036⁶ for Non-Migrated MPANs, and the REP-900 message for Migrated MPANs (as agreed with us). The data shall be emailed to info@aurora-utilities.co.uk .

2.73. We require details of reactive power imported or exported to be provided for all Measurement Class C and E sites for Non-Migrated MPANs, and for all Migrated MPANs with a Connection Type of 'L', 'H' or 'E'. It is also required for CVA sites and Exempt Distribution Network boundaries with difference metering. We reserve the right to levy a charge on Users who fail to provide such reactive data. In order to estimate missing reactive data, a power factor of 0.9 lag will be applied to the active consumption in any half hour.

Out of area use of system charges

2.74. Aurora Utilities Limited does not have a Distribution Service Area.

Licensed distribution network operator charges

2.75. Licensed Distribution Network Operator (LDNO) charges are applied to LDNOs who operate Embedded Networks within our Distribution Services Area.

2.76. The charge structure for LV and HV Designated Properties embedded in networks operated by LDNOs will mirror the structure of the 'All-the-way' charge and is dependent upon the voltage of connection of each embedded network to our Distribution System. The relevant charge structures are set out in Annex 4.

2.77. Where a NHH metered MPAN has an invalid Settlement combination, the 'LDNO HV: Domestic Aggregated with Residual' fixed and unit charges will be applied as default until the invalid combination is corrected. Where there are multiple SSC/TPR combinations for Non-Migrated MPANs, the default 'LDNO HV: Domestic Aggregated with Residual' fixed and unit charges will be applied for each invalid SSC/TPR combination.

⁶ Data Transfer Catalogue available from <https://www.electralink.co.uk/dtc-catalogue>

2.78. The charge structure for Designated EHV Properties embedded in networks operated by LDNOs will be calculated individually using the EDCM. The relevant charge structures are set out in Annex 2.

2.79. For Nested Networks the relevant charging principles set out in DCUSA Schedule 21 will apply.

Licence exempt distribution networks

2.80. The Electricity and Gas (Internal Market) Regulations 2011⁷ introduced obligations on owners of licence exempt distribution networks (sometimes called private networks) including a duty to facilitate access to electricity and gas suppliers for Customers within those networks.

2.81. When Customers (both domestic and commercial) are located within a licence exempt distribution network and require the ability to choose their own Supplier this is called 'third party access'. These embedded Customers will require an MPAN so that they can have their electricity supplied by a Supplier of their choice.

2.82. Licence exempt distribution networks owners can provide third party access using either full settlement metering or the difference metering approach⁸.

Full settlement metering

2.83. This is where a licence exempt distribution network is set up so that each embedded installation has an MPAN and Metering System and therefore all Customers purchase electricity from their chosen Supplier. In this case there are no Settlement Metering Systems at the boundary between the licensed Distribution System and the licence exempt distribution network.

2.84. In this approach our UoS charges will be applied to each MPAN.

⁷ The Electricity and Gas (Internal Market) Regulations 2011 available from <http://www.legislation.gov.uk/uksi/2011/2704/contents/made>

⁸ Elaxon's guide is available from <https://bscdocs.elaxon.co.uk/guidance-notes/third-party-access-to-licence-exempt-distribution-networks>

Difference metering

2.85. This is where one or more, but not all, Customers on a licence exempt distribution network choose their own Supplier for electricity supply to their premises. Under this approach, the Customers requiring third party access on the licence exempt distribution network will have their own MPAN and must have a HH Metering System.

Shared Metering

2.86. This is where one or more Customers on a licence exempt distribution network choose their own Supplier for electricity supply to their premises, and the active import and/or active export meter readings at the boundary are apportioned between the Suppliers. Under this approach, the Customers requiring third party access on the licence exempt distribution network will have their own MPAN and must have a HH Metering System.

2.87. In this approach our UoS charges will be applied to each MPAN.

Gross settlement

2.88. Where one of our MPANs (prefix 45) is embedded within a licence exempt distribution network connected to our Distribution System, and difference metering is in place for Settlement purposes and we receive gross measurement data for the boundary MPAN, we will continue to charge the boundary MPAN Supplier for use of our Distribution System. No charges will be levied by us directly to the Customer or Supplier of the embedded MPAN(s) connected within the licence exempt distribution network.

2.89. We require that gross metered data for the boundary of the connection is provided to us. Until a new industry data flow is introduced for the sending of such gross data, gross metered data shall:

- be provided in a text file in the format of the D0036 or D0275 data flow;
- the text file shall be emailed to info@aurora-utilities.co.uk ;

- the title of the email should also contain the phrase “gross data for difference metered private network” and contain the metering reference specified by us in place of the Settlement MPAN; and
- the text filename shall be formed of the metering reference specified by us followed by a hyphen and followed by a timestamp in the format YYYYMMDDHHMMSS and followed by “.txt”.

2.90. For the avoidance of doubt, the reduced difference metered measurement data for the boundary connection that is to enter Settlement should continue to be sent using the Settlement MPAN.

[Net settlement

2.91. Where one of our MPANs (prefix 45) is embedded within a licence exempt distribution network connected to one of our Distribution Systems, and difference metering is in place for Settlement purposes, and we do **not** receive gross measurement data for the boundary MPAN, we will charge the boundary MPAN Supplier based on the net measurement for use of our Distribution System. Charges will also be levied directly to the Supplier of the embedded MPAN(s) connected within the licence exempt distribution network based on the actual data received.

2.92. The charges applicable for the embedded MPANs are unit charges only. These will be the same values as those at the voltage of connection to the licence exempt distribution network. The fixed charge and capacity charge, at the agreed MIC/MEC of the boundary MPAN, will be charged to the boundary MPAN Supplier.

3. Schedule of charges for use of the distribution system

- 3.1. Tables listing the charges for use of our Distribution System are published in annexes to this document.
- 3.2. These charges are also listed in a spreadsheet which is published with this statement and can be downloaded from <https://aurora-utilities.co.uk/>
- 3.3. Annex 1 contains the charges applied to LV and HV Designated Properties.
- 3.4. Annex 2 contains the charges applied to our Designated EHV Properties and charges applied to LDNOs for Designated EHV Properties connected to their Distribution Systems.
- 3.5. Annex 3 contains details of any preserved and additional charges that are valid at this time. Preserved charges are mapped to an appropriate charge and are closed to new Customers.
- 3.6. Annex 4 contains the charges applied to LDNOs in respect of LV and HV Designated Properties connected to their Distribution Systems.

4. Schedule of line loss factors

Role of line loss factors in the supply of electricity

- 4.1. Electricity entering or exiting our Distribution System is adjusted to take account of energy that is lost⁹ as it is distributed through the network. This adjustment does not affect distribution charges but is used in energy settlement to take metered consumption to a notional Grid Supply Point so that Suppliers' purchases take account of the energy lost on the Distribution System.
- 4.2. We are responsible for calculating the Line Loss Factors (LLFs) and providing these to Elexon. Elexon is the company that manages the BSC.
- 4.3. LLFs are used to adjust the Metering System volumes to take account of losses on the Distribution System.

Calculation of line loss factors

- 4.4. LLFs are calculated in accordance with BSCP128, which sets out the procedure and principles with which our LLF methodology must comply. It also defines the procedure and timetable by which LLFs are reviewed and submitted.
- 4.5. LLFs are calculated for a set number of time periods during the year using either a generic or site-specific method. The generic method is used for sites connected at LV or HV and the site-specific method is used for sites connected at EHV or where a request for site-specific LLFs has been agreed. Generic LLFs will be applied as a default to all new EHV sites until sufficient data is available for a site-specific calculation.

Where the usage profile for a given site contains insufficiently large consumption or generation volumes to enable calculation of realistic site-specific LLFs then a default calculation, or default replacement process shall be undertaken.

⁹ Energy can be lost for technical and non-technical reasons and losses normally occur by heat dissipation through power flowing in conductors and transformers. Losses can also reduce if a customer's action reduces power flowing in the distribution network. This might happen when a customer generates electricity and the produced energy is consumed locally.

A default replacement process shall be deemed to have been undertaken if a generic methodology is used where the following applies:

(a) A Site has multiple connections to the total system and the primary connection is at EHV but there is a subordinate connection that is not connected at EHV, then a generic methodology may be used for the subordinate connection (even if a site-specific LLF is used for the Site's primary connection); and

(b) The connection has a capacity of less than or equal to 1MVA

The definition of EHV used for LLF purposes differs from the definition used for defining Designated EHV Properties in the EDCM. The definition used for LLF purposes can be found in our LLF methodology, which can be found on the Elexon website¹⁰.

Publication of line loss factors

4.6. The LLFs used in Settlement are published on the Elexon Portal¹¹. The website contains the LLFs in standard industry data formats and in a summary form. A user guide with details on registering and using the portal is also available.

4.7. BSCP128 sets out the timetable by which LLFs are submitted and audited. The submission and audit occurs between September and December in the year prior to the LLFs becoming effective. Only after the completion of the audit at the end of December and BSC approval are the final LLFs published.

4.8. As this statement is published a complete year before the LLFs for the charging year have been produced, Annex 5 is intentionally left blank. This statement will be reissued with Annex 5 populated once the LLFs have been calculated and audited. This should typically be more than three months prior to the statement coming into force.

¹⁰ BSCP128: Production, Submission, Audit and Approval of Line Loss Factors
<https://www.elexon.co.uk/csd/bscp128-production-submission-audit-and-approval-of-line-loss-factors/>

¹¹ The Elexon Portal can be accessed from www.elexonportal.co.uk

- 4.9. When using the tables in Annex 5, reference should be made to the LLFC allocated to a Non-Migrated MPAN or to the DUoS Tariff ID allocated to a Migrated MPAN to find the appropriate values.

5. Notes for Designated EHV Properties

EDCM network group costs

- 5.1. Aurora Utilities Ltd do not have any designated EHV Properties.
- 5.2. A new connection will result in changes to current network utilisations, which will then form the basis of future prices. The charge determined in this statement will not necessarily be the charge in subsequent years because of the interaction between new and existing network connections and any other changes made to our Distribution System which may affect charges.

Charges for new Designated EHV Properties

- 5.3. Charges for any new Designated EHV Properties calculated after publication of the current statement will be published on our website in an addendum to that statement as and when necessary. The addendum will include charge information of the type found in Annex 2, and LLFs as found in Annex 5.
- 5.4. The form of the addendum is detailed in Annex 6 to this statement.
- 5.5. The new Designated EHV Properties' charges will be added to Annex 2 in the next full statement released.

Charges for amended Designated EHV Properties

- 5.6. Where an existing Designated EHV Property is modified and energised in the charging year, we may revise the EDCM charges for the modified Designated EHV Property. If revised charges are appropriate, an addendum will be sent to all relevant parties and published as a revised 'Schedule of Charges and other tables' spreadsheet on our website. The modified Designated EHV Property charges will be added to Annex 2 in the next full statement released.

Demand-side management

- 5.7. New or existing Designated EHV Property Customers may wish to offer part of their MIC to be interruptible by us (for active network management purposes

other than normal planned or unplanned outages) in order to benefit from any reduced UoS charges calculated using the EDCM.

- 5.8. Several options exist in which we may agree for some or the entire MIC to be interruptible. Under the EDCM the applicable demand capacity costs would be based on the MIC minus the capacity subject to interruption.
- 5.9. If you are interested in making part or all of your MIC interruptible as an integral irrevocable feature of a new connection or modification to an existing connection you should in the first instance contact our connections function;
- By email to info@aurora-utilities.co.uk
 - By telephone to +44 20 3023 0200
 - By writing to 5th Floor, Tower 42, 25 Old Broad Street, London, EC2 1HN

You must make an express statement in your application that you have an interest in some or all of the import capacity being interruptible for active network management purposes.

- 5.10. If you are proactively interested in voluntarily but revocably offering to make some or all of your existing connection's MIC interruptible you should in the first instance contact our info@aurora-utilities.co.uk.
- 5.11. A guide to Demand Side Management (DSM) is also available. This provides more information on the type of arrangement that might be put in place should you request to participate in DSM arrangements. This document is available by contacting the Control Room at the address in paragraph **Error! Reference source not found..**

6. Electricity distribution rebates

6.1. We have neither given nor announced any DUoS rebates to Users in the 12 months preceding the date of publication of this version of the statement.

7. Accounting and administration services

7.1. We reserve the right to impose payment default remedies. The remedies are as set out in DCUSA where applicable or else as detailed in the following paragraph.

7.2. If any invoices that are not subject to a valid dispute remain unpaid on the due date, late payment interest (calculated at base rate plus 8%) and administration charges may be imposed.

7.3. Our administration charges are detailed in the following table. These charges are set at a level which is in line with the Late Payment of Commercial Debts Act;

Size of Unpaid Debt	Late Payment Fee
Up to £999.99	£40.00
£1,000 to £9,999.99	£70.00
£10,000 or more	£100.00

8. Charges for electrical plant provided ancillary to the grant of use of system

8.1. None

9. Schedule of fixed adders to recover Supplier of Last Resort and Eligible Bad Debt pass-through costs

Supplier of Last Resort

9.1. In accordance with Standard Condition 38B ‘Last Resort Supply Payment Claims’ (‘SLC38B’) and Special Condition 6 ‘Pass-through expenditure’ (‘SpC6’) of our

Electricity Distribution Licence, our charges will recover the amount of payments in Regulatory Year t made in response to Last Resort Supply Payment claims.

Eligible Bad Debt

- 9.2. In accordance with SpC6, our charges will recover the amount of use of system bad debt the Authority has consented to be recovered. This represents use of system bad debt our charges are recovering on behalf of Independent Distribution Network Operators (IDNOs), in accordance with Standard Licence Condition 38C 'Treatment of Valid Bad Debt Claims' ('SLC38C'), and specifically paragraph 4 of that condition.

Tables of Fixed Adders

- 9.3. Tables listing the charges to recover Supplier of Last Resort and Eligible Bad Debt pass-through costs are published in Annex 7 to this document. The charges are shown for information only and are already included in the final charges.

10. Non-Final Demand Sites

Charges for Non-Final Demand Sites

10.1. A Non-Final Demand Site is charged an import tariff that excludes the residual cost element of charges. If the User wishes for a property to qualify for allocation to these tariffs, then the User must submit certification declaring that the property meets the required criteria as per DCUSA.

Process for submitting certification

10.2. This certification should take the form as set out in Appendix 3 and be submitted using the contact details in **Error! Reference source not found.2.**

We may, at our discretion, request a signed paper certificate from the User, in place of electronic. If requested, paper certification should be posted to the contact details in **Error! Reference source not found.2.**

10.3. Users should undertake reasonable endeavours to ensure the facts attested to in the certification are true. We may request documentation evidencing these endeavours, including where appropriate, photographs of metering positions or system diagrams, following receipt of the certification.

10.4. If we determine that the documentation provided does not sufficiently evidence the undertaking of reasonable endeavours, does not support the facts attested to in the certification, or if no documentation is received, we may at our discretion reject the certification as invalid. If the certification is rejected as invalid, then the property will not qualify as a Non-Final Demand Site.

Application of charges for Non-Final Demand Sites

10.5. A property will only be deemed to qualify as a Non-Final Demand Site, and be allocated charges as such, from the date on which we receive valid certification.

10.6. If a property that has previously been certified as a Non-Final Demand Site no longer satisfies the criteria as per DCUSA, then the User must inform us immediately.

10.7. For a property that has been previously certified as a Non-Final Demand Site, we will continue to apply the relevant no residual import tariff without the requirement for further certification, except in any one of the following circumstances:

- Where we have reason to believe that the property no longer qualifies as a Non-Final Demand Site; or
- Significant time has passed since the certification was submitted; or
- Where there is a change to the connection characteristics i.e. capacity change.

If such circumstances occur, we may request re-certification of the site, or reject the certification as invalid at our discretion.

10.8. When a property no longer meets the required criteria to qualify as a Non-Final Demand Site, we will change the allocation of charges accordingly from that point.

10.9. Please refer to the section 'Incorrectly allocated charges' if you believe the property has been incorrectly not allocated charges as a Non-Final Demand Site.

11. Back-up Connections

Charges for Back-up Connections

11.1. A Back-up Connection is charged an import tariff that excludes the residual cost element of charges. If the User wishes for a MPAN/MSID to qualify for allocation to these tariffs, then the User must provide evidence necessary to satisfy the definition of Back-up Connection as per DCUSA.

Process for providing evidence

11.2. Users should undertake reasonable endeavours to ensure the facts attested to in the request are true. We may request documentation evidencing these

endeavours, including where appropriate, photographs of metering positions or system diagrams.

- 11.3. If we determine that the documentation provided does not sufficiently evidence the undertaking of reasonable endeavours, does not support the facts attested to in the request, or if no documentation is received, we may at our discretion reject the evidence as invalid. If the evidence is rejected as invalid, then the property will not qualify as a Back-up Connection.

Application of charges for Back-up Connections

- 11.4. A MPAN/MSID will only be deemed to qualify as a Back-up Connection, and be allocated charges as such, from the first of the month following the date on which we receive valid evidence.

- 11.5. If a MPAN/MSID that has previously been appointed as a Back-up Connection no longer satisfies the criteria as per DCUSA, then the User must inform us immediately.

- 11.6. For a MPAN/MSID that has been previously certified as a Back-up Connection, we will continue to apply the relevant no residual import tariff without the requirement for further certification, except in any one of the following circumstances:

- Where we have reason to believe that the MPAN/MSID no longer qualifies as a Back-up Connection; or
- Significant time has passed since the evidence was submitted; or
- Where there is a change to the connection characteristics i.e. capacity change.

If such circumstances occur, we may request evidence to be provided again for the site, or reject the evidence as invalid at our discretion.

11.7. When a MPAN/MSID no longer meets the required criteria to qualify as a Back-up Connection, we will change the allocation of charges accordingly from that point.

11.8. Please refer to the section 'Incorrectly allocated charges' if you believe the MPAN/MSID has been incorrectly not allocated charges as a Back-up Connection.

Appendix 1 - Glossary

1.1. The following definitions, which can extend to grammatical variations and cognate expressions, are included to aid understanding:

Term	Definition
All-the-way Charge	A charge that is applicable to an end user rather than an LDNO. An end user in this context is a Supplier/User who has a registered MPAN or MSID and is using the Distribution System to transport energy on behalf of a Customer.
Back-up Connection	As defined in DCUSA Schedule 32.
Balancing and Settlement Code (BSC)	The BSC contains the governance arrangements for electricity balancing and settlement in Great Britain. An overview document is available from www.elexon.co.uk/ELEXON Documents/trading_arrangements.pdf .
Balancing and Settlement Code Procedure (BSCP)	A document of that title, as established or adopted and from time to time modified by the Panel in accordance with The Code, setting out procedures to be complied with (by Parties, Party Agents, BSC Agents, BSCCo, the Panel and others) in, and other matters relating to, the implementation of The Code;
Common Distribution Charging Methodology (CDCM)	The CDCM used for calculating charges to Designated Properties as required by standard licence condition 13A of the Electricity Distribution Licence.
Connection Agreement	An agreement between an LDNO and a Customer which provides that that Customer has the right for its connected installation to be and remain directly or indirectly connected to that LDNO's Distribution System
Central Volume Allocation (CVA)	As defined in the BSC.
Connection Type	Defines the physical connection as one of four valid types for metered supplies: 'W' Whole Current; 'L' Low Voltage (LV) Current Transformer; 'H' High Voltage (HV) Current Transformer; or 'E' Extra High Voltage (EHV) Current Transformer (E). It will also include a value of 'U' for unmetered connections.

Term	Definition
Customer	<p>A person to whom a User proposes to supply, or for the time being supplies, electricity through an exit point, or from whom, a User or any relevant exempt supplier, is entitled to recover charges, compensation or an account of profits in respect of electricity supplied through an exit point;</p> <p>Or</p> <p>A person from whom a User purchases, or proposes to purchase, electricity, at an entry point (who may from time to time be supplied with electricity as a Customer of that User (or another electricity supplier) through an exit point).</p>
Designated EHV Properties	As defined in standard condition 13B of the Electricity Distribution Licence.
Designated Properties	As defined in standard condition 13A of the Electricity Distribution Licence.
Distribution Connection and Use of System Agreement (DCUSA)	<p>The DCUSA is a multi-party contract between the licensed electricity distributors, suppliers, generators and Offshore Transmission Owners of Great Britain.</p> <p>It is a requirement that all licensed electricity distributors and suppliers become parties to the DCUSA.</p>

Distributor IDs	<p>These are unique IDs that can be used, with reference to the MPAN, to identify your LDNO. The charges for other network operators can be found on their website.</p>		
	ID	Distribution Service Area	Company
	10	East of England	UK Power Networks
	11	East Midlands	National Grid Electricity
	12	London	UK Power Networks
	13	Merseyside and North Wales	Scottish Power
	14	Midlands	National Grid Electricity
	15	Northern	Northern Powergrid
	16	North Western	Electricity North West
	17	Scottish Hydro Electric (and embedded networks in other areas)	Scottish Hydro Electric Power Distribution plc
	18	South Scotland	Scottish Power
	19	South East England	UK Power Networks
	20	Southern Electric (and embedded networks in other areas)	Southern Electric Power Distribution plc
	21	South Wales	National Grid Electricity
	22	South Western	National Grid Electricity
	23	Yorkshire	Northern Powergrid
	24	All	Independent Power Networks
	25	All	ESP Electricity
	26	All	Energetics Electricity Ltd
	27	All	The Electricity Network Company Ltd
	29	All	Harlaxton Energy Networks
	30	All	Peel Electricity Networks Ltd
	31	All	UK Power Distribution Ltd
	32	All	Energy Assets Networks Limited
	33	All	Eclipse Power Networks Ltd
	34	All	Murphy Power Distribution Ltd

Term	Definition		
	35	All	Fulcrum Electricity Assets Ltd
	36	All	Vattenfall Networks Ltd
	37	All	Forbury Assets Limited
	38	All	Indigo Power Limited
	39	All	Stark Infra-Electricity Ltd
	40	All	Utility Assets Limited
	42	All	Advanced Electricity Networks
	43	All	IDCSL
	45	All	Aurora Utilities Limited
Distribution Network Operator (DNO)	An electricity distributor that operates one of the 14 distribution services areas and in whose Electricity Distribution Licence the requirements of Section B of the standard conditions of that licence have effect.		
Distribution Services Area	The area specified by the Gas and Electricity Markets Authority within which each DNO must provide specified distribution services.		
Distribution System	<p>The system consisting (wholly or mainly) of electric lines owned or operated by an authorised distributor that is used for the distribution of electricity from:</p> <ul style="list-style-type: none"> • Grid Supply Points or generation sets or other entry points <p>to the points of delivery to:</p> <ul style="list-style-type: none"> • Customers or Users or any transmission licensee in its capacity as operator of that licensee’s transmission system or the Great Britain (GB) transmission system and includes any remote transmission assets (owned by a transmission licensee within England and Wales) <p>that are operated by that authorised distributor and any electrical plant, electricity meters, and metering equipment owned or operated by it in connection with the distribution of electricity, but does not include any part of the GB transmission system.</p>		
DUoS Tariff Id	An identifier assigned to an SVA metering system which is used to assign the use of system charges for Migrated MPANs		

Term	Definition
EHV Distribution Charging Methodology (EDCM)	The EDCM used for calculating charges to Designated EHV Properties as required by standard licence condition 13B of the Electricity Distribution Licence.
Electricity Distribution Licence	The Electricity Distribution Licence granted or treated as granted pursuant to section 6(1) of the Electricity Act 1989.
Electricity Distributor	Any person who is authorised by an Electricity Distribution Licence to distribute electricity.
Embedded Network	An electricity Distribution System operated by an LDNO and embedded within another Distribution System.
Embedded Network report for DUoS – aggregated data	A report of data by IDNO’s DUoS Tariff ID and by IDNO providing counts of MPANs and units consumed
Engineering Recommendation P2/6	A document of the Energy Networks Association, which defines planning standards for security of supply and is referred to in Standard Licence Condition 24 of the Electricity Distribution Licence.
Entry Point	A boundary point at which electricity is exported onto a Distribution System from a connected installation or from another Distribution System, not forming part of the total system (boundary point and total system having the meaning given to those terms in the BSC).
Exit Point	A point of connection at which a supply of electricity may flow from the Distribution System to the Customer’s installation or User’s installation or the Distribution System of another person.
Extra High Voltage (EHV)	Nominal voltages of 22kV and above.
Final Demand Site	As defined in DCUSA Schedule 32.
Gas and Electricity Markets Authority (GEMA)	As established by the Utilities Act 2000.
Grid Supply Point (GSP)	A metered connection between the National Grid Electricity Transmission system and the licensee’s distribution system at which electricity flows to or from the Distribution System.
GSP group	A distinct electrical system that is supplied from one or more GSPs for which total supply into the GSP group can be determined for each half hour.

Term	Definition
High Voltage (HV)	Nominal voltages of at least 1kV and less than 22kV.
Industry Standing Data (ISD)	Industry Standing Data (ISD) is the reference data used in Settlement processes under MHHS.
Invalid Settlement Combination	A Settlement combination that is not recognised as a valid combination in market domain data - see Market Domain Data - Elexon BSC
kVA	Kilovolt ampere.
kVArh	Kilovolt ampere reactive hour.
kW	Kilowatt.
kWh	Kilowatt hour (equivalent to one "unit" of electricity).
LDSO report for DUoS – aggregated data	A report of data by DUoS Tariff ID and Supplier providing counts of MPANs and units consumed
Licensed Distribution Network Operator (LDNO)	The holder of a Licence to distribute electricity.
Line Loss Factor (LLF)	The factor that is used in Settlement to adjust the metering system volumes to take account of losses on the distribution system.
Line Loss Factor Class (LLFC)	An identifier assigned to an SVA metering system which is used to assign the LLF and use of system charges for Non-Migrated MPANs.
Load Factor	$= \frac{\text{annual consumption (kWh)}}{\text{maximum demand (kW)} \times \text{hours in year}}$
Low Voltage (LV)	Nominal voltages below 1kV.
Market Domain Data (MDD)	MDD is a central repository of reference data available to all Users involved in Settlement. It is essential to the operation of SVA trading arrangements. More information can be found here Market Domain Data - Elexon BSC

Term	Definition
Market Segment	<p>Market Segment is derived from the Meter Type and Connection Type using a defined set of business rules.</p> <p>There are three Market Segments:</p> <ul style="list-style-type: none"> • Smart and Non-Smart (Including Smart Meters with Settlement Period level data available, Smart Meters with only Register Readings available and Non-Smart Meters with Register Readings); • Advanced (which are Advanced Metering Systems with Settlement Period level data available); • Unmetered
Market-Wide HH Settlement (MHHS)	<p>Market-wide Half-Hourly Settlement (MHHS) is a key enabler of the flexibility to support the transition to Net Zero. The MHHS Programme will contribute to a more cost-effective electricity system, encouraging more flexible use of energy and helping consumers lower their bills.</p>
Maximum Export Capacity (MEC)	<p>The MEC of apparent power expressed in kVA that has been agreed can flow through the entry point to the Distribution System from the Customer's installation as specified in the connection agreement.</p>
Maximum Import Capacity (MIC)	<p>The MIC of apparent power expressed in kVA that has been agreed can flow through the exit point from the Distribution System to the Customer's installation as specified in the connection agreement.</p>

Term	Definition
Measurement Class	<p>A classification of Metering Systems used in the BSC which indicates how consumption is measured, i.e.:</p> <ul style="list-style-type: none"> • Measurement Class A – non-half hourly metering equipment; • Measurement Class B – non-half hourly unmetered supplies; • Measurement Class C – half hourly metering equipment at or above 100kW premises; • Measurement Class D – half hourly unmetered supplies; • Measurement Class E – half hourly metering equipment below 100kW premises with CT; • Measurement Class F – half hourly metering equipment at below 100kW premises with CT or whole current, and at domestic premises; and • Measurement Class G – half hourly metering equipment at below 100kW premises with whole current and not at domestic premises.
Meter Timeswitch Code (MTC)	<p>MTCs are three digit codes allowing suppliers to identify the metering installed in Customers' premises. They indicate whether the meter is single or multi-rate, pre-payment or credit, or whether it is 'related' to another meter. Further information can be found in MDD.</p>
Metering Point	<p>The point at which electricity that is exported to or imported from the licensee's Distribution System is measured, is deemed to be measured, or is intended to be measured and which is registered pursuant to the provisions of the REC. For the purposes of this statement, GSPs are not 'Metering Points'.</p>
Metering Point Administration Number (MPAN)	<p>A number relating to a Metering Point under the REC.</p>
Metering System	<p>Particular commissioned metering equipment installed for the purposes of measuring the quantities of exports and/or imports at the exit point or entry point.</p>
Metering System Identifier (MSID)	<p>MSID is a term used throughout the BSC and its subsidiary documents and has the same meaning as MPAN as used under the REC.</p>

Term	Definition
Migrated MPANs	Migration refers to the process by which MPANs are migrated from the legacy arrangements to the new MHHS arrangements.
Nested Networks	This refers to a situation where there is more than one level of Embedded Network and therefore nested Distribution Systems between LDNOs (e.g. host DNO→primary nested DNO→ secondary nested DNO→customer).
Non-Final Demand (NFD) Site	As defined in DCUSA Schedule 32.
Non-Migrated MPANs	This refers to the status when an MPAN is on the legacy arrangements and before migrating under MHHS.
Ofgem	Office of Gas and Electricity Markets – Ofgem is governed by GEMA and is responsible for the regulation of the distribution companies.
Profile Class (PC)	A categorisation applied to NHH MPANs and used in settlement to group customers with similar consumption patterns to enable the calculation of consumption profiles.
Retail Energy Code (REC)	A code that consolidates the switching arrangements historically set out in the Master Registration Agreement (MRA) and the Supply Point Administration Agreement (SPAA) (for gas) into one dual-fuel code. Provides a governance mechanism to manage the processes established between electricity suppliers and distribution companies to enable electricity suppliers to transfer customers. It includes terms for the provision of Metering Point Administration Services (MPAS) Registrations.
Settlement	The determination and settlement of amounts payable in respect of charges (including reconciling charges) in accordance with the BSC.
Settlement Class (SC)	The combination of Profile Class, Line Loss Factor Class, Time Pattern Regime and Standard Settlement Configuration, by Supplier within a GSP group and used for Settlement.
Standard Settlement Configuration (SSC)	A standard metering configuration relating to a specific combination of Time Pattern Regimes.

Term	Definition
Supercustomer	The method of billing Users for use of system on an aggregated basis, grouping together consumption and standing charges for all similar NHH metered Customers or aggregated HH metered Customers. Also referred to as Aggregate billing.
Supercustomer DUoS Report	A report of profiled data by Settlement Class providing counts of MPANs and units consumed.
Supplier	An organisation with a supply licence responsible for electricity supplied to and/or exported from a metering point.
Supplier Volume Allocation (SVA)	As defined in the BSC.
Time Pattern Regime (TPR)	The pattern of switching behaviour through time that one or more meter registers follow.
Unmetered Supplies	Exit points deemed to be suitable as unmetered supplies as permitted in the Electricity (Unmetered Supply) Regulations 2001 and where operated in accordance with BSC procedure 520 ¹² .
Use of System Charges	Charges which are applicable to those parties which use the Distribution System.
User	Someone that has a use of system agreement with the DNO e.g. a supplier, generator or other LDNO.

¹² Balancing and Settlement Code Procedures are available from <http://www.elexon.co.uk/pages/bscps.aspx>

Appendix 2 - Guidance notes¹³

Background

- 1.1. The electricity bill from your Supplier contains an element of charge to cover electricity distribution costs. This distribution charge covers the cost of operating and maintaining a safe and reliable Distribution System that forms the 'wires' that transport electricity between the national transmission system and end users such as homes and businesses. Our Distribution System includes overhead lines, underground cables, as well as substations and transformers.
- 1.2. In most cases, your Supplier is invoiced for the distribution charge and this is normally part of your total bill. In some cases, for example business users, the Supplier may pass through the distribution charge as an identifiable line item on the electricity bill.
- 1.3. Where electricity is generated at a premises your Supplier may receive a credit for energy that is exported on to the Distribution System. These credits are intended to reflect that the exported generation may reduce the need for traditional demand led reinforcement of the Distribution System.
- 1.4. Understanding your distribution charges could help you reduce your costs and increase your credits. This is achieved by understanding the components of the charge to help you identify whether there may be opportunities to change the way you use the Distribution System.

Meter point administration

- 1.5. We are responsible for managing the electricity supply points that are connected to our Distribution System. Typically, every supply point is identified by a Meter Point Administration Number (MPAN). A few supply points may have more than one MPAN depending on the metering configuration (e.g. a school which may have an MPAN for the main supply and an MPAN for catering).

¹³ These guidance notes are provided for additional information and do not form part of the application of charges.

- 1.6. The full MPAN is a 21 digit number, preceded by an 'S' and includes supplementary data. The MPAN applicable to a supply point is found on the electricity bill from your Supplier. This number enables you to establish who your electricity distributor is, details of the characteristics of the supply and importantly the distribution charges that are applicable to your premises.
- 1.7. The 21-digit number is normally presented in two sections as shown in the following diagram. The top section is supplementary data which gives information about the characteristics of supply, while the bottom 'core' is the unique identifier.

Full MPAN diagram

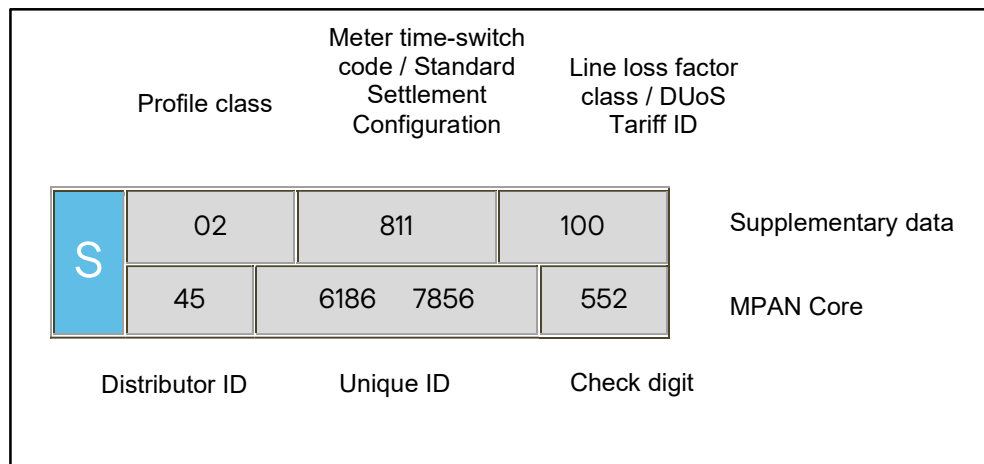

- 1.8. Generally, you will only need to know the Distributor ID and LLFC/DUoS Tariff ID to identify the distribution charges for your premises. However, there are some premises where charges are specific to that site. In these instances, the charges are identified by the MPAN core. The Distributor ID for Aurora Utilities Ltd is 45. Other Distributor IDs can be referenced in the glossary.
- 1.9. Additionally, it can be useful to understand the profile class provided in the supplementary data. The profile class will be a number between 00 and 08. The

following list provides details of the allocation of profile classes to types of customers:

- '01' – Domestic customers with unrestricted supply
- '02' – Domestic customers with restricted load, for example off-peak heating
- '03' – Non-domestic customers with unrestricted supply
- '04' – Non-domestic customers with restricted load, for example off-peak heating
- '05' – Non-domestic maximum demand customers with a Load Factor of less than 20%
- '06' – Non-domestic maximum demand customers with a Load Factor between 20% and 30%
- '07' – Non-domestic maximum demand customers with a Load Factor between 30% and 40%
- '08' – Non-domestic maximum demand customers with a Load Factor over 40% or non-half hourly metered generation customers
- '00' – Half-hourly metered, demand and generation customers (including all Migrated MPANs)

1.10. Unmetered Supplies will be allocated to profile class 01, 08 or 00 depending on the type of load or the measurement method of the load.

1.11. The allocation of the profile class will affect your charges for Non-Migrated MPANs. If you feel that you have been allocated the wrong profile class, please contact your Supplier as they are responsible for this.

Your charges

1.12. All distribution charges that relate to our Distributor ID 45 are provided in this statement.

1.13. You can identify your charges by referencing your LLFC/DUoS Tariff ID, from Annex 1. If the MPAN is for a Designated EHV Property, then the charges will be found in Annex 2. In a few instances, the charges may be contained in Annex 3 or

Annex 6. When identifying charges in Annex 2, please note that some LLFC/DUoS Tariff IDs have more than one charge. In this instance, you will need to select the correct charge by cross-referencing with the MPAN core provided in the table.

- 1.14. Once you have identified which charge structure applies to your MPAN then you will be able to calculate an estimate of your distribution charge using the calculator provided in the spreadsheet 'Schedule of charges and other tables' found in the sheet called 'Charge Calculator'. This spreadsheet can be downloaded from <https://aurora-utilities.co.uk/>.

Reducing your charges

- 1.15. The most effective way to reduce your energy charges is to reduce your consumption by switching off or using more energy efficient appliances. However, there are also other potential opportunities to reduce your distribution charges; for example, it may be beneficial to shift demand or generation to a better time period. Demand use is likely to be cheaper outside peak periods and generation credits more beneficial during peak periods, although the ability to directly benefit will be linked to the structure of your supply charges.
- 1.16. The calculator mentioned above provides the opportunity to establish a forecast of the change in distribution charges that could be achieved if you are able to change any of the consumption related inputs.

Reactive power and reactive power charges

- 1.17. Reactive power is a separately charged component of connections that are half hourly metered. Reactive power charges are generally avoidable if 'best practice' design of the properties' electrical installation has been provided in order to maintain a power factor between 0.95 and unity at the Metering Point.
- 1.18. Reactive Power (kVAh) is the difference between working power (active power measured in kW) and total power consumed (apparent power measured in kVA).

Essentially it is a measure of how efficiently electrical power is transported through an electrical installation or a Distribution System.

- 1.19. Power flowing with a power factor of unity results in the most efficient loading of the Distribution System. Power flowing with a power factor of less than 0.95 results in much higher losses in the Distribution System, a need to potentially provide higher capacity electrical equipment and consequently a higher bill for you the consumer. A comparatively small improvement in power factor can bring about a significant reduction in losses since losses are proportional to the square of the current.
- 1.20. Different types of electrical equipment require some 'reactive power' in addition to 'active power' in order to work effectively. Electric motors, transformers and fluorescent lighting, for example, may produce poor power factors due to the nature of their inductive load. However, if good design practice is applied then the poor power factor of appliances can be corrected as near as possible to source. Alternatively, poor power factor can be corrected centrally near to the meter.
- 1.21. There are many advantages that can be achieved by correcting poor power factor. These include: reduced energy bills through lower reactive charges, lower capacity charges and reduced power consumption and reduced voltage drop in long cable runs.

Site-specific EDCM charges

- 1.22. A site classified as a Designated EHV Property is subject to a locational-based charging methodology (referred to as EDCM) for higher voltage network users. Distributors use one of two approved approaches: Long Run Incremental Cost (LRIC) or Forward Cost Pricing (FCP); we use the FCP. The EDCM will apply to Customers connected at EHV or connected at HV and metered at a HV Substation.

1.23. EDCM charges and credits are site-specific, reflecting the degree to which the local and higher voltage networks have the capacity to serve more demand or generation without the need to upgrade the electricity infrastructure. The charges also reflect the networks specifically used to deliver the electricity to the site as well as the usage at the site. Generators with non-intermittent output and deemed to be providing beneficial support to our networks may qualify to receive credit.

1.24. The charges under the EDCM comprise of the following individual components:

a) **Fixed charge (pence/MPAN/day)** - This charge recovers operational costs associated with those connection assets that are provided for the 'sole' use of the customer and a residual amount to ensure recovery of our regulated allowed revenue.

b) **Capacity charge (pence/kVA/day)** - This charge comprises the relevant FCP component, the National Grid Electricity Transmission cost and other regulated costs.

Capacity charges are levied on the MIC, MEC, and any exceeded capacity. You may wish to review your MIC or MEC periodically to ensure it remains appropriate for your needs as you may be paying for more capacity than you require. If you wish to make changes contact us via the details in paragraph **Error! Reference source not found.**

The FCP cost is locational and reflects our assessment of future network reinforcement necessary at the voltage of connection (local) and beyond at all higher voltages (remote) relevant to the customer's connection. This results in the allocation of higher costs in more capacity congested parts of the network reflecting the greater likelihood of future reinforcement in these areas, and the allocation of lower costs in less congested parts of the network. The local FCP cost is included in the capacity charge.

Our regulated costs include direct and indirect operational costs. The capacity charge recovers these costs using the customer usage profile and the relevant assets being used to transport electricity between the source substation and customer's Metering Point.

c) **Super-red unit charge (pence/kWh)** - This charge recovers the remote FCP component. The charge is positive for import and negative for export which means you can either reduce your charges by minimising consumption or increasing export at those times. The charge is applied to consumption during the Super-red time period as detailed in Annex 2.

- 1.25. Future charge rates may be affected by consumption during the Super-red period, therefore reducing consumption in the Super-red time period may be beneficial.
- 1.26. **Reactive Power** - The EDCM does not include a separate charge component for any reactive power flows (kVAr) for either demand or generation. However, the EDCM charges do reflect the effect on the network of the customer's power factor; for example, unit charges can increase if your site power factor is poor (lower than 0.95). Improving your site's power factor will also reduce the maximum demand (kVA) for the same power consumed in kW thus providing scope to reduce your agreed capacity requirements.

Appendix 3 – Non-Final Demand Site Certificate

A certificate set out in the form of the example shown below should be submitted to confirm that a site qualifies as a Non-Final Demand Site.

Non-Final Demand Site Certificate of Compliance	
<p>This is to certify that the Metering System listed below qualifies as compliant with the criteria of a Non-Final Demand Site, for the purposes of Use of System charges, and that:</p> <p>The property is a Single Site at which either or both Electricity Storage and/or Electricity Generation occurs (whether the facility(ies) at the site are operating or being commissioned, repaired or decommissioned), and that:</p> <ul style="list-style-type: none">a) has an export MPAN and an import MPAN with associated metering equipment which only measures export from Electricity Storage and/or Electricity Generation and import for or directly relating to Electricity Storage and/or Electricity Generation (and not export from another source and/or import for another activity); andi) if registered in an MPAS Registration System, is subject to certification from a Supplier Party that the site meets the criteria in paragraph (a) above, which certificate has been provided to the DNO/IDNO Party; orii) if registered in CMRS, is subject to certification from the Customer (or its CVA Registrant) that the site meets the criteria in paragraph (a) above, which certificate has been provided to the DNO/IDNO Party. <p>For the purposes of this declaration, the term Non-Final Demand Site has the meaning given to it in the DCUSA.</p>	
Metering System Site Address:	
Qualifying Import MPAN/MSID(s)	Qualifying Export MPAN/MSID(s)

I declare that I understand the qualification requirements and certify that the above Metering System meets the criteria of a Non-Final Demand Site.

Authorised signatory:

Name and designation:

On behalf of company:

Date:

Annex 1 - Schedule of charges for use of the distribution system by LV and HV Designated Properties, and Unmetered Supplies

Annex 2 - Schedule of charges for use of the distribution system by Designated EHV Properties (including LDNOs with Designated EHV Properties/end-users)

Annex 3 - Schedule of charges for use of the distribution system by preserved/additional LLF classes

**Annex 4 - Charges applied to LDNOs with LV and HV end-users
Annex 5 - Schedule of line loss factors**

Annex 6 - Charges for New or Amended Designated EHV Properties

Annex 7 - Final Supplier of Last Resort and Bad Debt Pass-through Costs

As Aurora Utilities Limited operate across all DNO regions, spreadsheets for the annexes detailed above have been created for each DNO area and are available to download from <https://aurora-utilities.co.uk/> or can be requested by email from info@aurora-utilities.co.uk